

SPECIFICATIONS

MODEL # 3601
VIBRATING HORN

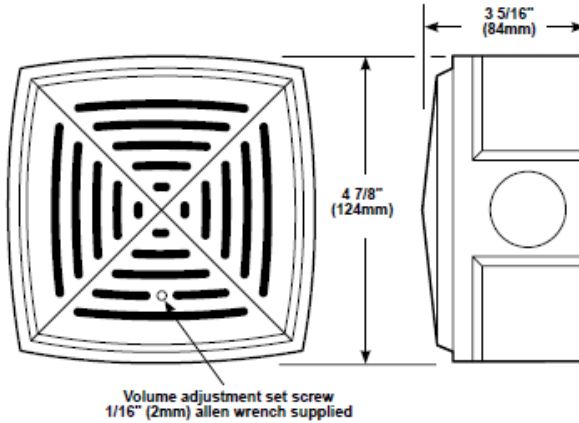

MODEL	3601	3601-230	3601-12	3601-24
OPERATING VOLTAGE	120 VAC, 50/60Hz	240 VAC, 50/60Hz	+12 VDC	+24 VDC
CURRENT	0.13 A	0.07 A	0.27 A	0.16 A
POWER	15.6 VA	16.8 VA	3.2 VA	3.8 VA
OUTPUT AT 10 FT (3.05 m)	78 to 103 dB		78 to 101 dB	
OUTPUT AT 30 FT (9.15 m)	68 to 93 dB		68 to 91 dB	
OUTPUT AT 70 FT (21.34 m)	61 to 86 dB		61 to 84 dB	
OUTPUT AT 100 FT (30.48 m)	58 to 83 dB		58 to 81 dB	
MATERIAL AND FINISH	Horn housing: Heat flowed epoxy finish die-cast, gray. Horn mounting box: Heat flowed epoxy finish die-cast, gray.			
ADJUSTMENT	Volume adjustment using set screw located on grille front			
DIMENSIONS	4-7/8 x 4-7/8" x 3-5/16" (124 mm x 124 mm x 84 mm)			
MOUNTING	Mounts on 3/4" NPT conduit or to any flat surface			
ENVIRONMENTAL	NEMA 4X / 12 / 12K rated enclosure			
CERTIFICATIONS	UL 464, CSA Certified.			
SHIPPING WEIGHT	5 lbs (2 kg).			